

What are Noise Measurements?

Noise measurements allow the determination of the four Noise Parameters of a device (transistor).

Noise Parameters: These are four numbers that fully describe the noise behaviour of an active or passive device (twoport) at a given frequency. For practical reasons we use the following quantities as Noise Parameters:

Minimum Noise Figure (Fmin): This is the smallest Noise Figure that the device can reach at a given frequency and bias, if it is optimally matched at the source.

Equivalent Noise Resistance (Rn): This is a number with the dimension Ohm that indicates how fast the Noise Figure increases when we mismatch the input (source).

Optimum Noise Reflection Factor (Topt), is often used also as Optimum Admittance Yopt: Is the source admittance required for the DUT to perform Fmin ; (Yopt=Gopt+jBopt), 2 parameters.

The Noise Figure does not depend on the Load impedance presented to the device . It only depends on the Source Impedance. There exist a simple relation between the four Noise Parameters:

$$\text{Noise Figure } F(Y_s) = F_{\min} + (R_n/G_s) * |Y_s - Y_{\text{opt}}|^2 \quad (1)$$

where $Y_s = G_s + jB_s$. This is the equation of a set of isometric circles on the Smith Chart (Noise Circles) for which the value of the Noise Figure is the Level on each Circle.

This Circle Representation is only possible because the Noise behaviour of transistors is a Small Signal Phenomenon.

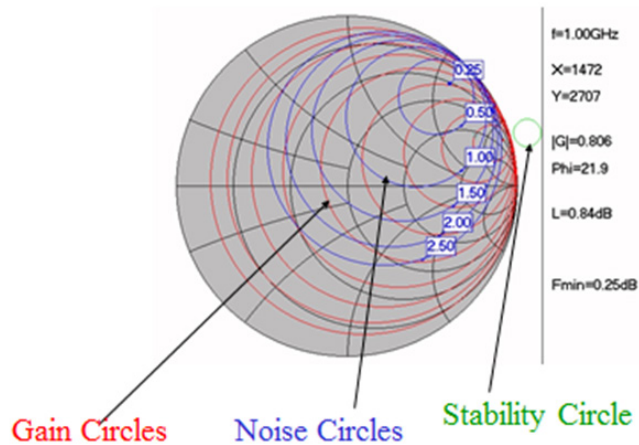

Measurement of the Noise Parameters: The 4 Noise Parameters can be determined if we measure the Noise Figure of a device at a minimum of 4 different source impedances.

Because of errors associated with the extremely low level noise measurements (the typical noise power of a transistor is about -110 dBm in 1 MHz bandwidth = the Noise Power is directly proportional to the Bandwidth) we, in general, measure at more than 4 impedances and average the measured data. 7 to 10 impedances are typically sufficient for the determination of the four noise parameters at each frequency.

The setup required to measure the Noise Parameters includes: - A Noise Analyzer (HP 8970 or 8975) or a Spectrum Analyzer- A Noise Source - A Programmable Tuner - A mixer and Local Oscillator (for $f > 1.8\text{GHz}$) - Isolators, bias tees etc.

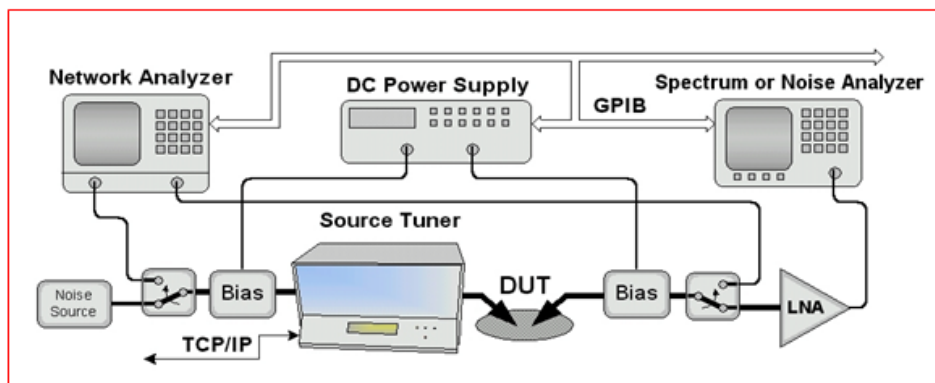

Contrary to Load Pull measurements, in Noise Measurements it is not absolutely required the Tuner used to be pre-calibrated. It can be set to a number of positions and readings can be taken, both of the Noise Figures and the Tuner positions. If the tuner is then characterized at those positions using a Network Analyzer, the 4 Noise Parameters can be calculated. This is only possible because of equation (1). If the tuner is pre-calibrated, of course this facilitates a lot the operation and the result can be computed immediately. Again, this method is, theoretically possible but cumbersome and a non pre- calibrated tuner will not permit to tune to the minimum Noise Figure, it will only permit to compute it.

Important: In Large Signal (Load Pull) an equation like (1) does not exist, because the behaviour of the devices is non-linear, ie. the gain of the transistor changes during the excursion of the sinusoidal signal. Consequently we need to know, during the measurement, what the loss of the tuner is, otherwise we cannot find the optimum Gain (or Power). This has as a consequence that for Load Pull measurements the tuners must be pre-calibrated .

Effect of Second Stage on Noise: The Noise Figure of a chain of amplifiers mostly depends on the first stage, especially if this has high gain. The effect of the following stages is divided by the gain of the preceding stages. The formula of FRIIS describes this as follows:

$$F_{total} = F_1 + (F_2 - 1) / G_1 + (F_3 - 1) / (G_1 * G_2) \dots \quad (2).$$

where G1 and G2 are the available gains of stage 1 and 2 respectively.

In a Noise Measurement setup we measure Ftotal and have to correct for the second stage (receiver) effect using calibration techniques.

Noise Temperature Tn: Is the temperature (in Degrees Kelvin) of a resistance connected at the input of the device, that will generate as much noise power at the output of the device as the device itself.

$$F = 1 + T_n / T_0 \text{ where } T_0 = 290K (17^\circ C) \dots \quad (3).$$

Example for Tn: NF=1dB => Tn=75.1K, NF=0.5dB => Tn=35.4K.

Note: we usually express noise figure F linear and NF in decibel: F=2 corresponds to NF=3dB.