

Product Note 41

Computer Controlled Microwave Tuner - CCMT

CCMT is a measurement system for Noise, Small Signal and Power characterization of transistors and other microwave components as a function of microwave impedance, dc bias, RF power and frequency. It measures the four Noise Parameters, DC-parameters (IV-Curves), S-parameters and nonlinear quantities such as Power, Gain, Intermod, Efficiency, Gain Compression, Adjacent Channel Power (ACPR) and more. The heart of the CCMT system is wideband, accurate and reliable electro-mechanical tuners of the CCMT series. The CCMT series of tuners includes coaxial models from 0.2 to 50 GHz and waveguide models from 26.5 to 110 GHz. The tuners generate repeatable reflection factors larger than 0.9 (VSWR \approx 20:1) and support RF power up to 50 Watt (CW) and more than 1kW (peak) at VSWR 10:1 with APC-7 connectors and over 100 Watt (CW) with N-connectors (see table 1). In combination with programmable harmonic tuners (PHT), the CCMT system can optimize fundamental and harmonic impedances up to 65 GHz.

CCMT includes all required hardware and Windows[®](¹) software components for complete system integration using an IBM-PC compatible computer, GPIB controlled instruments and some other components such as test fixtures, wafer probe stations, bias tees, isolators, attenuators, power and low noise amplifiers and RF switches. More than 100 GPIB instruments including all network analyzers are supported. Complete calibration and measurement software allows for a straight-forward integration, data processing and circuit design.



Figure 1: 2-40 GHz programmable tuner, model CCMT-4002-2C

CCMT can also be configured and shipped as an Integrated Load Pull or Noise Measurement System **ILPS** (see Product Note 47). ILPS includes all required components and remote RF switches to allow for 'in-situ' calibration of the tuners on a wafer probe station and load pull or noise measurements.

(1) Windows[®] 3.1, -95 and -NT

The electro-mechanical CCMT tuners

• Description

The CCMT are electromechanical instruments that allow precise positioning of probes in a slotted transmission line, in order to generate repeatable complex microwave reflection factors. The frequencies at which this coaxial concept is being used by Focus Microwaves covers 200 MHz to 50 GHz in different multioctave bands and tuner types. Tuners using waveguide cover standard WR bands from 26.5 to 110 GHz.

The positioning of the probes is obtained using stepper motors and vertical and horizontal screw translation mechanisms driven by timing belts. All CCMT tuners use the same vertical anti-backlash mechanism with a resolution of 0.75 or 1.5 μm per motor step (smallest addressable distance).

Horizontally the step size varies between 1.25 and 25 μm depending on the frequency of operation in order to obtain an optimum "tuning speed/resolution" ratio. The use of timing belts to control axis positioning minimizes the vibrations translated from the stepper motors to the axis and thus to the probes (in case the tuners are used on a wafer probe station).

• Backlash / Testing

Both tuner axes use spring-loaded anti-backlash drives. In addition the software may be directed to compensate for backlash by reversing the drive direction in older tuner models.

Due to the anti-backlash and spring loaded driving mechanism, the carriage of the vertical axis has no play at all relative to the housing of the tuner. The initialization state of the tuners is detected using mechanical precision microswitches. These switches are specified to accuracies of $\pm 1 \mu\text{m}$ over 1,000,000 switching cycles but each one is nevertheless tested individually over 2000 cycles by FOCUS, before being used in a tuner.

After assembly and alignment each tuner is tested nonstop for 24 hours over the maximum horizontal and vertical travel range and its performance is verified before final release. This corresponds to average load pull testing of about 150 days (at an average of 30 full tests per day). The tuners are delivered fully calibrated with the calibration data on a diskette in the complete frequency range; accuracy verification data and protocols are being stored in a central computer and are available on request.

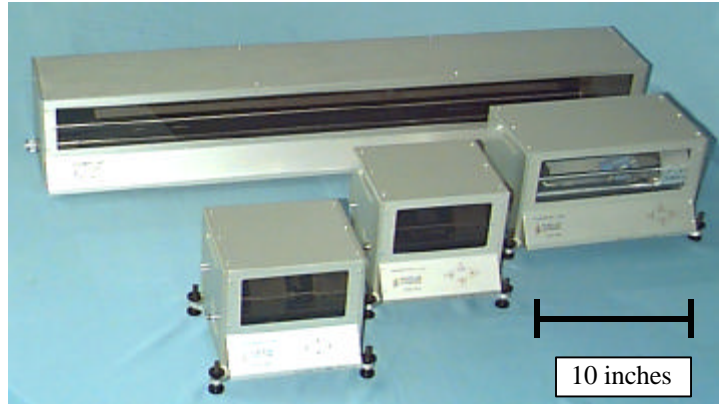

Figure 2 : CCMT models, from the back: **1802-2C** (0.2 to 18 GHz), **1808** (0.8 to 18 GHz), **4006** (6 to 40 GHz) and **4006-2H** (fundamental 6 to 40 GHz. harmonic 12-44 GHz)



Figure 3: High power 0.8-18 GHz tuner with N-connectors, model **1808-N**

• Microwave Probes (Slugs)

The microwave probes are slotted in order to make spring loaded contact with the walls of the airline for perfect and consistent RF grounding. They are made out of Bronze or Beryllium Copper. This choice of material is made in order to ensure permanent sliding and self-lubrication of the contact with the walls of the transmission lines, which are made of special hard aluminum (use of "yellow on white metal" self-lubrication). Observations of such structures over the last 15 years do not show significant wear of the probes or the transmission line. The choice of this structure has been made in order to ensure repeatability and insensitivity to mechanical vibrations and, by consequence, RF impedance jitter ("microphonism").

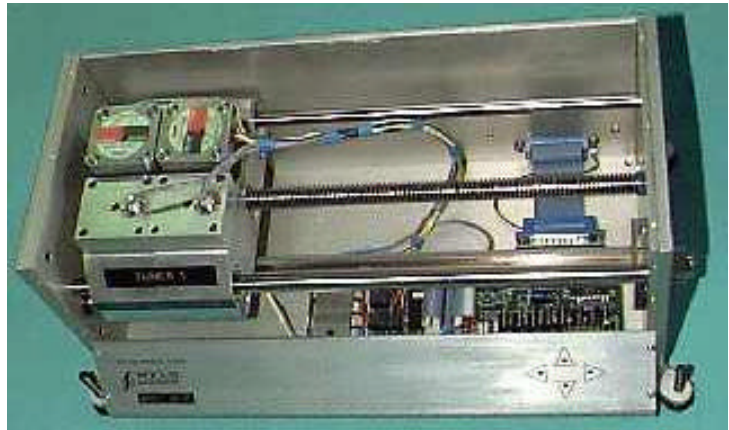

Figure 4: Internal structure of **dual axis multioctave tuner** (0.7-18 GHz)

• Maintenance Requirements

The tuners are practically "maintenance-free". If they are put into use after having been idle for a period of time, the movement alone will carry away possible residual deposits and the tuners will recover their original behaviour. The tuners are very rugged. They can be opened and closed without any effect on their performance. Experience shows that they, in general, can survive a fall from a laboratory table onto the floor without significant alterations of the calibration data, except if there is damage to the connectors. The tuners include all of their driver electronics. Control from the PC is through TTL pulses whereas the average current drawn by the tuners is nearly constant. This eliminates interference with other instruments and allows control with long cables for an easier setup. Standard cables are up to 12 feet; longer cables are also possible.

• Handling and Calibration

The tuners should be handled properly. For instance over-torquing the connectors is very detrimental to their accuracy and longevity. If well maintained the tuners do not need to be recalibrated more than once every few months. There is no reasonable way to guarantee the RF properties of a moving mechanical device in changing laboratory conditions like temperature, humidity, transportation, unrecorded vibrations etc. except by recalibrating it or verifying its performance periodically (every 1 to 3 months) on a network analyzer. If left unused for a longer period of time, the tuners should be run a couple of hours first and then recalibrated.

Special attention has to be paid to the calibration of the network analyzer (VNA) in order to avoid "strange phenomena" like "tuners with gain" or "points outside the Smith Chart". All these phenomena are due to inadequate VNA calibrations. FOCUS strongly recommends the use of TRL calibration techniques throughout the frequency range from 200 MHz to 110 GHz for consistent and accurate test results.

Available Wideband CCMT Tuners (special bands available on request)

Model	Frequency	VSWR (opt)	Connector	Structure
CCMT - 304	0.4 - 3.0 GHz	>10:1 (20:1)	GPC-7, N	1 probe / 1 axis
CCMT - 306	0.6 - 3.0 GHz	>10:1 (20:1)	GPC-7, N	1 probe / 1 axis
CCMT - 1808	0.8 - 18.0 GHz	>10:1 (20:1)	GPC-7, N	2 probes / 1 axis*
CCMT - 1808-2C	0.8 - 18.0 GHz	>10:1 (20:1)	GPC-7, N	2 probes / 2 axis
CCMT - 1804-2C	0.45 - 18.0 GHz	>10:1 (20:1)	GPC-7, N	2 probes / 2 axis
CCMT- 1802-2C	0.2- 18.0 GHz	>10:1 (20:1)	GPC-7, N	2 probes / 2 axis
CCMT - 2604	4.0 - 26.5 GHz	>10:1 (15:1)	3.5 mm	1 probe / 1 axis
CCMT - 2602-2C	2.5 - 26.5 GHz	>10:1 (15:1)	3.5 mm	2 probes / 2 axis
CCMT - 4006	6.0 - 40.0 GHz	>10:1 (15:1)	2.9 mm (K)	1 probe / 1 axis
CCMT - 4002-2C	2.0 - 40.0 GHz	>10:1 (15:1)	2.9 mm (K)	2 probes / 2 axis
CCMT – 5003-2C	3.0 - 50.0 GHz	>10:1	2.4 mm	2 probe / 2 axis
CCMT - 4026	26.5 - 40.0 GHz	>15:1	WR-28 /Ka	1 probe / 1 axis
CCMT - 5033	33.0 - 50.0 GHz	>15:1	WR-22 /Q	1 probe / 1 axis
CCMT - 6040	40.0 - 60.0 GHz	>15:1	WR-19 /L	1 probe / 1 axis
CCMT – 7550	50.0 - 75.0 GHz	>15:1	WR-15 /V	1 probe / 1 axis
CCMT – 11075	75.0 - 110 GHz	>12:1	WR-10 /W	1 probe / 1 axis

Harmonic Programmable Tuners, basic models (**)

PHT-1808 (harmonic only)	2fo = 1.6 – 18 GHz 3fo = 2.4 – 18 GHz	30:1 – 100:1	GPC-7, N	2 resonant probes / 2 axis
PHT-4006 (harmonic only)	2fo = 12 – 45 GHz 3fo = 18 – 45 GHz	20:1 – 40:1	2.9 mm (K)	2 resonant probes/ 2 axis
CCMT-1808-2H (fundam. &harmonic)	fo = 0.8 – 18 GHz 2fo = 1.6 – 18 GHz	10:1 – 15:1 (fo) 30:1 – 50:1 (2fo)	GPC-7, N	1 wideband probe 1 resonant probe 2 axis
CCMT-4006-2H (fundam.&harmonic)	fo = 6 – 40 GHz 2fo = 12 – 45 GHz	10:1 (fo) 20:1- 40:1 (2fo)	2.9 mm (K)	1 wideband probe 1 resonant probe 2 axis

Table 1: Available CCMT and Harmonic Tuner models.

Tuner size: W=8"-36", H=6.0", D=7.4", Weight=4.5 - 12 kg. Control plug can be on the tuner's side for easier integration on probe stations. {Note * } : A probe-change by the user is needed at 3 GHz.

(N): Tuners can be equipped with N-connectors for CW power \approx 100 W or higher @VSWR>10:1

(opt) : Tuners can be aligned for high VSWR (option -HR) on special order.

{Note **} :Harmonic tuners up to 50 and 65 GHz available using 2.4 and 1.85 mm (V) connectors.

Tuner Accuracy and Reproducibility

CCMT tuners are very accurate. Their accuracy exceeds the requirements for repeatable Load Pull and Noise measurements for short and long term operation (several months).

Because the CCMT system provides the unique feature of being able to synthesize any interpolated impedance on the Smith Chart (not only calibrated points), we distinguish three types of accuracy:

- Repeatability of Reflection Factor
- System accuracy and Repeatability
- Tuning Accuracy (Performance Verification)

• Repeatability of Reflection Factor

The tuners are moved several times to the same horizontal and vertical position. The S-parameters are measured and saved. The error is then computed from $\delta S_{ij} = 20 \log_{10}(|S_{ij} - S_{ij,av}|)$ and plotted in histograms as shown in figure 5. The obtained errors vary between -75 and -55 dB for different VSWR and frequencies. The short-term measurement repeatability of the VNA itself is between -75 and -70 dB.

• System Accuracy and Repeatability

Very important, from the User point of view, is Overall System Performance, Reproducibility, Consistency of the Results and Reliability. The CCMT system generates reliable and consistent data over long periods of time with or without re-calibration.

Figure 6 shows an example in form of two overlapping sets of measured data. They correspond to ACPR data, (which themselves are highly sensitive measurements), made using a CCMT load pull system before and after two months of continuous operation. Similar or better repeatability data is obtained for Gain, Output Power, Efficiency etc..

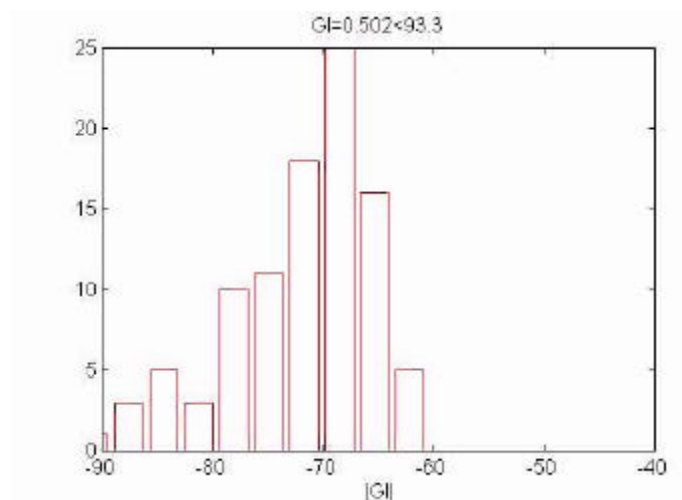

Figure 5: Repeatability of S11 [dB]

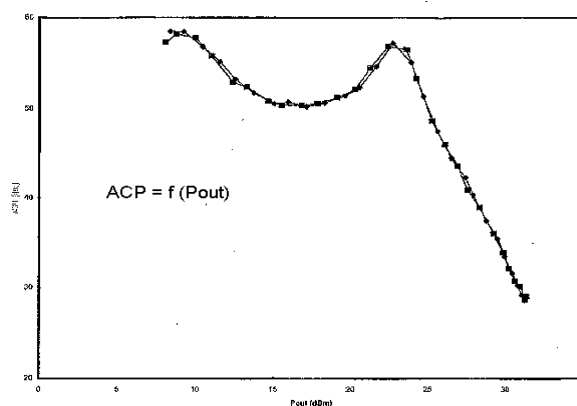

Figure 6 : ACPR measurement repeatability of CCMT Load Pull system after two months of operation

• Tuning Accuracy (Performance Verification)

The CCMT system has the basic capability, which is not available from other tuner systems, of providing continuous accurate tuning over the entire Smith Chart taking full advantage of the CCMT's high resolution tuning capability ($\approx 10,000,000$ impedance states at 1 GHz), instead of some impedance switching to precalibrated points. To be able to do this the CCMT software uses proprietary calibration routines and interpolation algorithms, which best describe the tuner's physical behaviour.

The **Verification Test Results** shown below have been measured on typical production units. The test is applied systematically to all tuners before shipment; it consists of sending the tuner to 25 IMPEDANCES (not physical positions !) on the Smith Chart at $\Gamma=0.65$, equally spaced in phase, and comparing the reading of the Network Analyzer to the tuned impedance. All tuned points are interpolated points, so the error shown includes both tuner repeatability and interpolation accuracy. This test is performed several times and the error registered is the absolute value of the vector difference between measured and synthesized reflection factor (expressed in dB).

<u>PERFORMANCE VERIFICATION</u>						
<u>Tuner Model 1808 (0.8 – 18 GHz, APC-7)</u>						
Calibrated at 181 points						
Cycle => Tuning Error [dB] (25 points / freq)						
GHz	1	2	3	4	5	Average
4.0	-57.8	-43.8	-57.2	-51.3	-48.6	-51.7
6.0	-54.2	-47.3	-54.1	-46.6	-51.7	-50.8
8.0	-40.9	-48.3	-41.7	-47.1	-45.8	-44.8
10.0	-54.4	-41.3	-49.8	-39.4	-44.4	-45.9
12.0	-45.1	-48.5	-42.8	-46.3	-40.3	-44.6
13.0	-43.0	-52.2	-45.7	-44.9	-54.8	-48.1
14.0	-41.6	-51.5	-40.0	-46.6	-37.9	-43.5
15.0	-53.2	-39.4	-49.0	-36.9	-44.6	-44.6
16.0	-55.8	-38.4	-47.6	-36.5	-43.9	-44.5
17.0	-42.9	-46.5	-41.1	-50.7	-40.0	-44.2
18.0	-38.0	-51.8	-38.9	-48.8	-41.0	-43.7
<u>Tuner Model 4006 (6. 0– 40 GHz, K)</u>						
Calibrated at 181 points						
GHz	1	2	3	4	5	Average
.....
38.0	-38.0	-39.4	-41.6	-42.4	-38.8	-40.0
39.0	-39.0	-40.9	-39.9	-41.7	-39.1	-40.1
40.0	-38.0	-39.9	-37.4	-39.9	-40.2	-39.1

Table 2: Overall tuning accuracy of a typical CCMT production unit.

Tuning Dynamic Range

CCMT tuners use one or two rf probes to generate reflection. Wide probes operate at low frequencies and create multiple reflections at higher frequencies. Narrow probes operate only at higher frequencies and have low pass character. Ultra wideband tuners (2 - 40 GHz or 0.7 – 18 GHz ..) use two carriages and two probes that can be used alternatively in order to cover instantaneously the full bandwidth. Figures 7 and 8 show examples of such tuning behaviour.

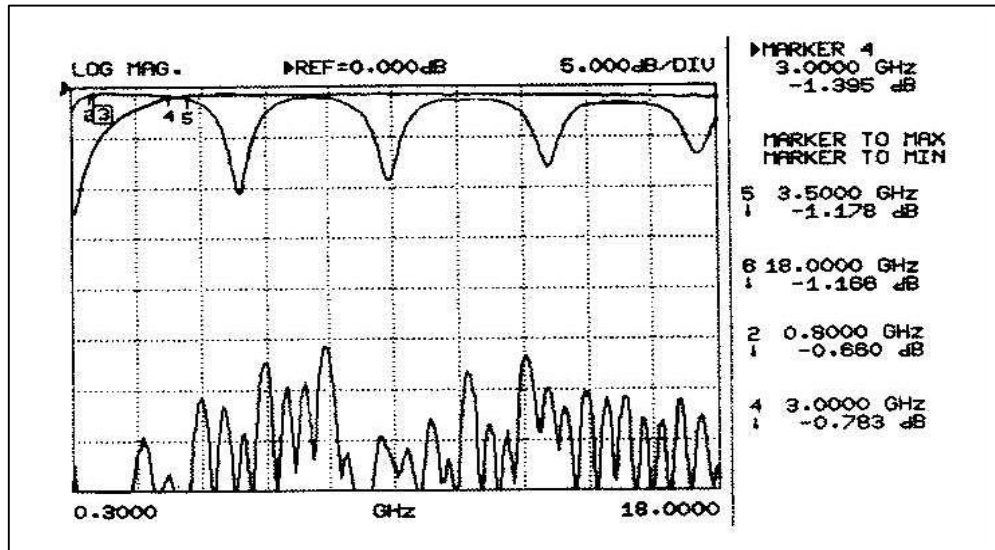

Figure7: Typical CCMT-1808 Min/Max Tuning (the flat response corresponds to a short, high frequency probe, whereas the multiple reflections originate from the wide, low frequency probe)

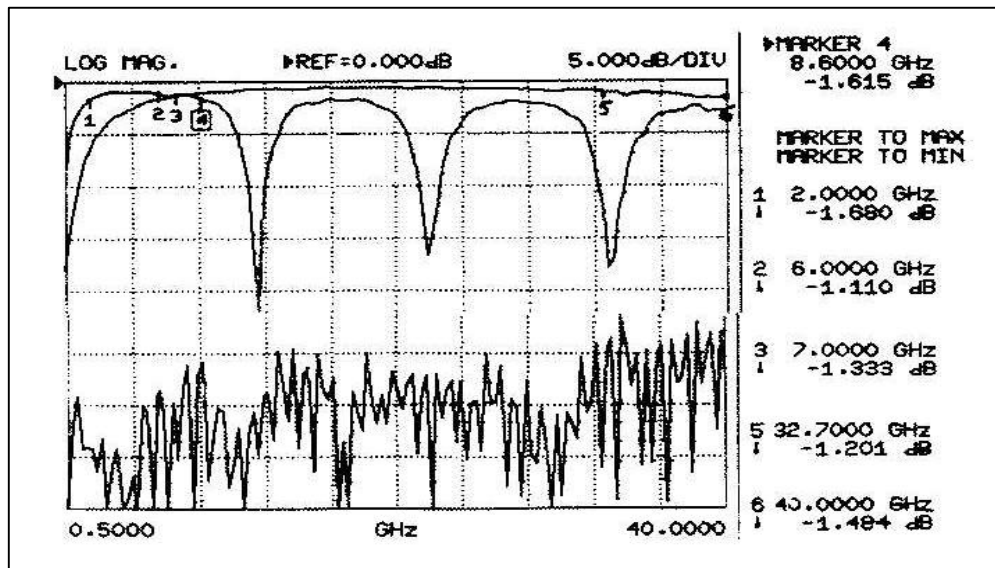

Figure 8: Typical CCMT-4002-2C Min/Max Tuning Range (the flat response corresponds to a short, high frequency probe, whereas the multiple reflections originate from the wide, low frequency probe)



Figure 9: W-band (75-110GHz) programmable tuner with wafer-probe support bracket (see also fig. 12)

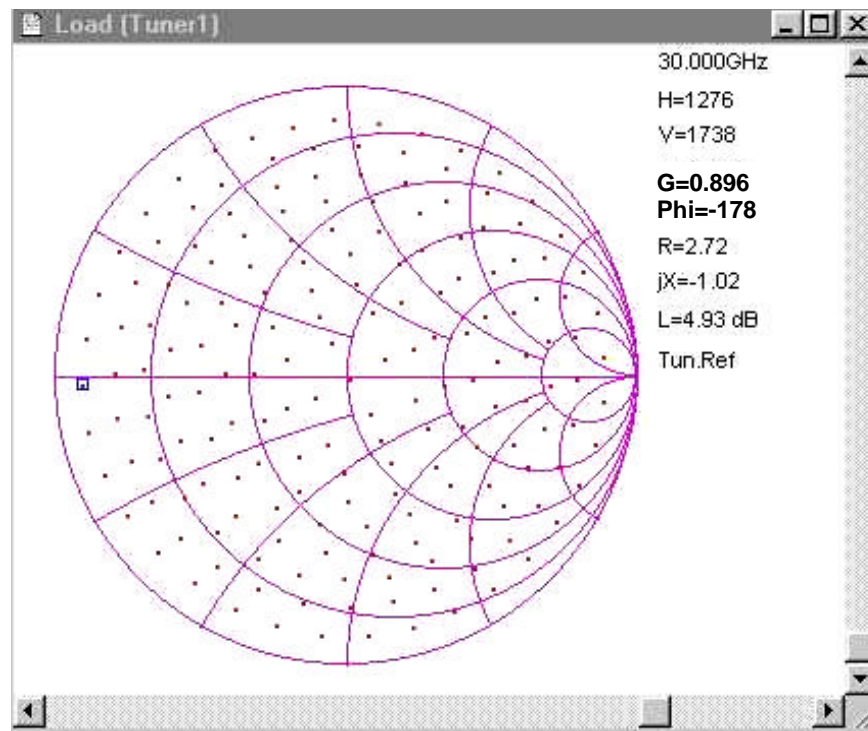

Figure 10: CCMT-4002-2C (2 to 40 GHz) typical distribution of calibrated points at 30 GHz. The same distribution of calibration points is generated at all frequencies from 200 MHz to 110 GHz and allows accurate interpolation algorithms to be used for continuous impedance tuning.

The programmable tuners can be used to make either Noise or Power measurements.

Noise Measurements using CCMT

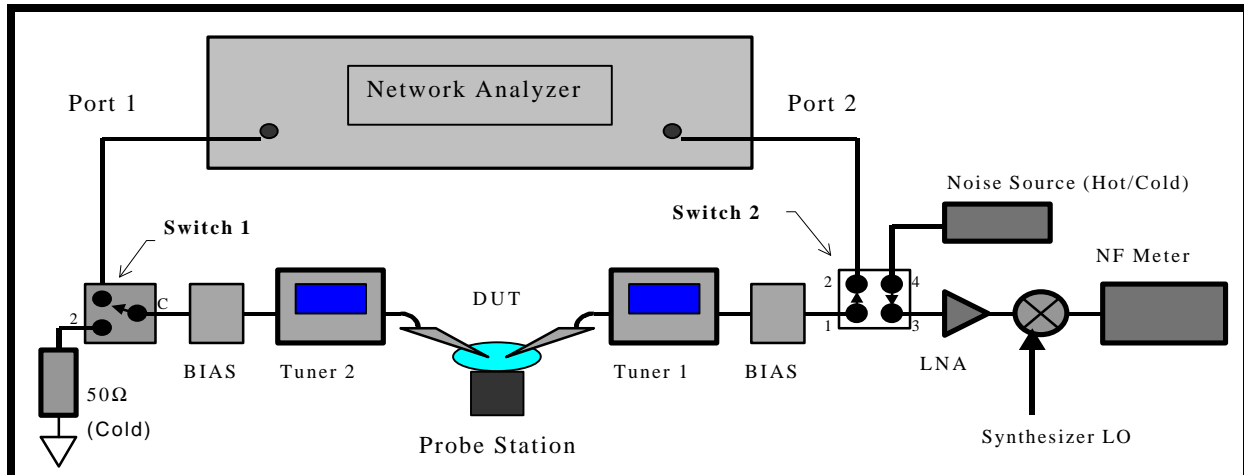

Figure 11 : Noise Source Measurement Setup, using 'Cold Noise Source' technique.

The Noise measurement software determines the four noise parameters at frequencies from 200 MHz to 110 GHz, both in test fixture or on-wafer. An automatic search routine allows you to search and find the optimum noise figure directly. The software allows 'in-situ' tuner and receiver calibrations and uses 'cold' and 'hot-cold' Noise Source measurement techniques for accurate noise parameter measurements up to millimeterwave frequencies. The effect of 'double sideband' measurement errors, due to differences in the Gain of the DUT at the two-sideband frequencies, is considered during the selection of the source impedances (see Appl. Note 19: 'On Wafer Noise Measurements...').

The tuners and the receiver can be calibrated "in-situ" by switching both ports to the network analyzer and inserting a "thru-line" standard in place of the DUT. RF-switch control is provided using the FOCUS Switch Control Box (SCB), see also page 18. Special probe station brackets are available from FOCUS, in order to mount millimeterwave tuners on the probe station.

FOCUS tuners and software are being used successfully for test fixture and on-wafer noise measurements from 200 MHz up to 110 GHz.

On wafer millimeterwave noise setups require biasable waveguide probes, for which FOCUS supplies the required mounting hardware.



Fig 12: On-wafer Noise tests at 94 GHz using CCMT-11075

Noise Measurement Methods

The CCMT system can be used to measure the four noise parameters of any transistor from 200 MHz to 110 GHz using either the "hot-cold" or the "cold" noise source method.

During the "hot-cold" method the noise source is switched "on" and "off" and the noise power ratio (Y-factor) at the output of the setup is measured. Using previous receiver calibrations (formula of FRIIS) the DUT noise figure can be then extracted for each source impedance. During the "cold" method the noise source is switched "on" and "off" only in order to calibrate the noise figure of the receiver. Measuring the noise power at the output of the receiver and knowing the gain of the DUT allows you to compute its noise figure as a function of the source impedance. Doing so for a number of source impedances (at least 4, typically 7 to 12 for some redundancy in the measurement) yields the four noise parameters at any given frequency.

- the Y-factor measurement technique (**HOT-COLD**)

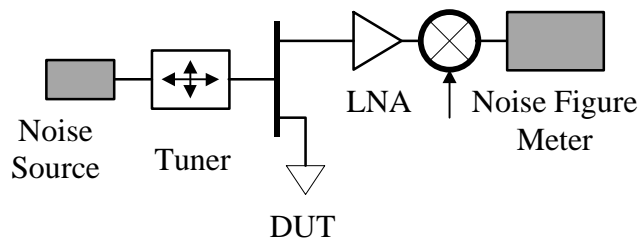

- the 'Cold-Source' measurement technique (**COLD**)

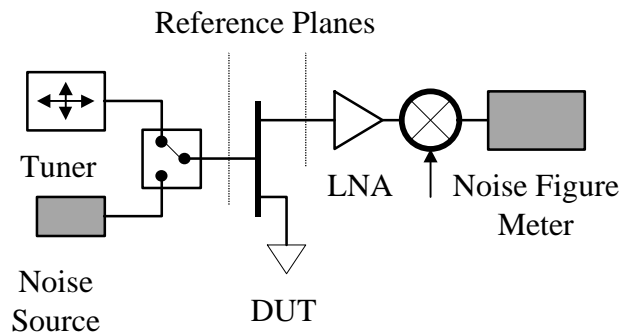

Figure 13 : Principle of 'Cold ' and 'Hot-Cold' Noise Measurement techniques

Both the "hot-cold" and the "cold" measurement method have their advantages and inconveniences: In the "hot-cold" method the tuner losses are an important component that may create inaccuracies, especially at high Γ -source. Also non-linearities in the noise receiver may become important because of the potentially high bandwidth. In the "cold" method the "S" parameters of the DUT must be determined very accurately at the time of the measurement. This implies that the "cold" method can only be used "in-situ" where the "S" parameters of the DUT can be measured immediately before the noise measurement itself, by switching over to the network analyzer. For complete details on both methods used by the CCMT software please refer to Application Notes AN-1-90 ('Hot-Cold') and AN-19 ('Cold').

Noise Measurement Results

The following plots and tables show typical results of noise measurements of the CCMT system, made on wafer using a 2604 (4-26.5 GHz) tuner.

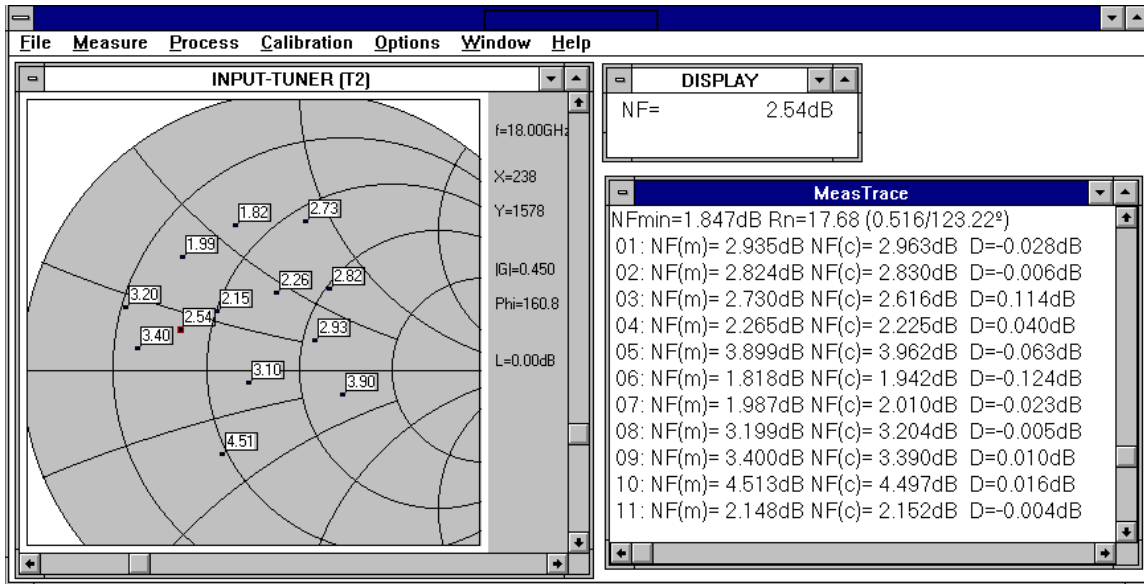

Figure 14: NF_{min} measured and calculated using WinNoise ('Cold' noise source)

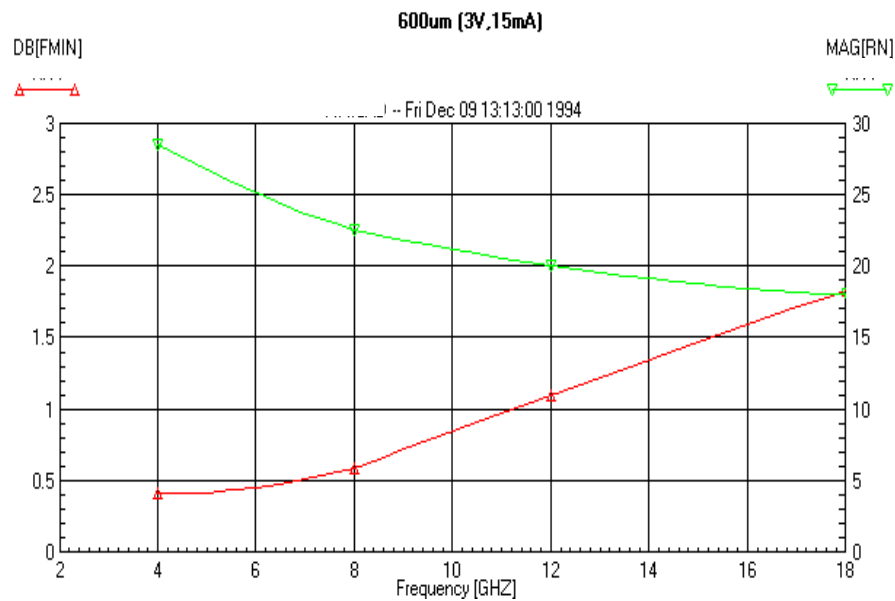

Figure15: Measured NF_{min} and equivalent $Rn[\Omega]$, from 4 to 18 GHz

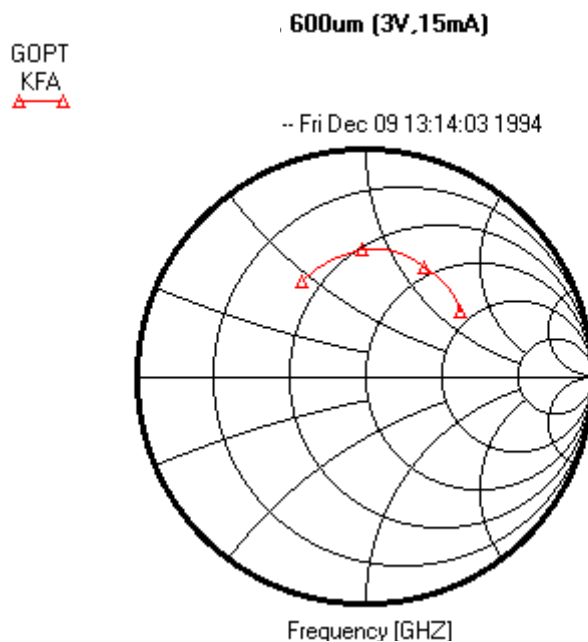

Figure 16: Γ_{opt} at 4, 8, 12 & 18 GHz

The results may also be presented in tabular format as shown below:

```

!
! Fri Dec 09 13:12:45 1994
!
!FREQ Fmin[dB] - Rn ---- MAG ---- ANG ---- NF[dB] --
4.000 0.41100 28.5000 0.50700 34.6500 1.39726
4.500 0.41324 27.5586 0.51617 37.8968 1.40534
5.000 0.42139 26.6719 0.52409 41.2211 1.41754
5.500 0.43542 25.8398 0.53082 44.6175 1.43434
6.000 0.45528 25.0625 0.53645 48.0793 1.45619
6.500 0.48087 24.3398 0.54106 51.5991 1.48355
7.000 0.51211 23.6719 0.54478 55.1686 1.51681
7.500 0.54887 23.0586 0.54771 58.7788 1.55638
8.000 0.59100 22.5000 0.55000 62.4200 1.60261
.....
.....
13.000 1.22448 19.5208 0.55208 97.2577 2.39091
13.500 1.28630 19.3031 0.54742 100.090 2.46109
14.000 1.34784 19.1000 0.54247 102.860 2.53098
14.500 1.40910 18.9115 0.53737 105.578 2.60094
15.000 1.47007 18.7375 0.53223 108.252 2.67137
15.500 1.53077 18.5781 0.52715 110.888 2.74268
16.000 1.59118 18.4333 0.52225 113.493 2.81526
16.500 1.65130 18.3031 0.51760 116.070 2.88953
17.000 1.71115 18.1875 0.51330 118.621 2.96592
17.500 1.77072 18.0865 0.50941 121.148 3.04484
18.000 1.83000 18.0000 0.50600 123.650 3.12672
    
```

Power Measurements using CCMT

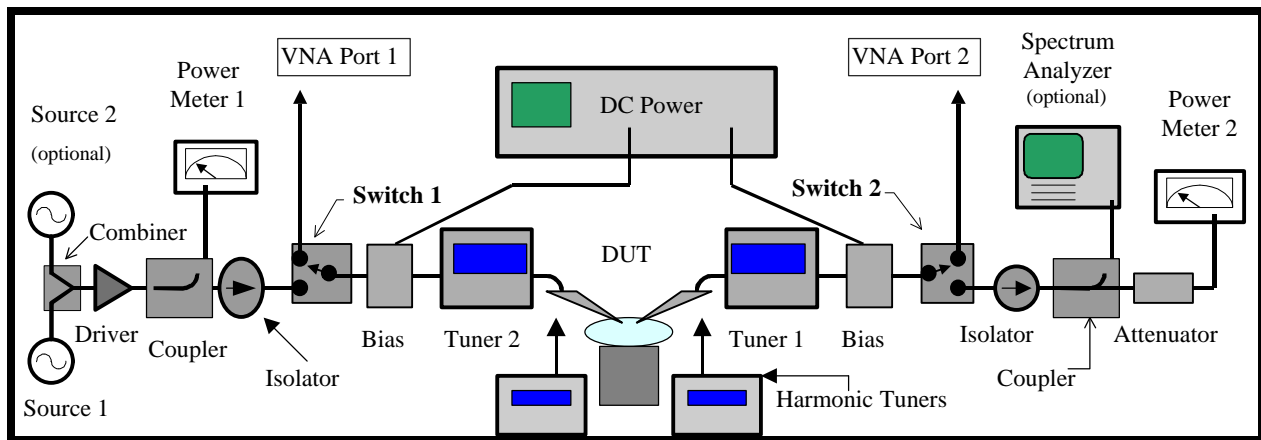

Figure 17 : Typical Setup for ‘in-situ’ tuner, fixture calibration and measurement of Power, Gain, Efficiency, AM/PM, Intermod and ACPR. Harmonic Tuners can be inserted between DUT and Tuners 1,2.

The Power measurement software allows manual and automatic measurements in order to optimize for source or load impedance conditions at fundamental and harmonic frequencies and to generate constant parameter contours. The data includes: Input and Output Power, Gain, Gain Compression, third and higher order Intermod and Intercept, Efficiency, DC Power, Adjacent Channel Power Ratio, AM/PM and Harmonic Loads.

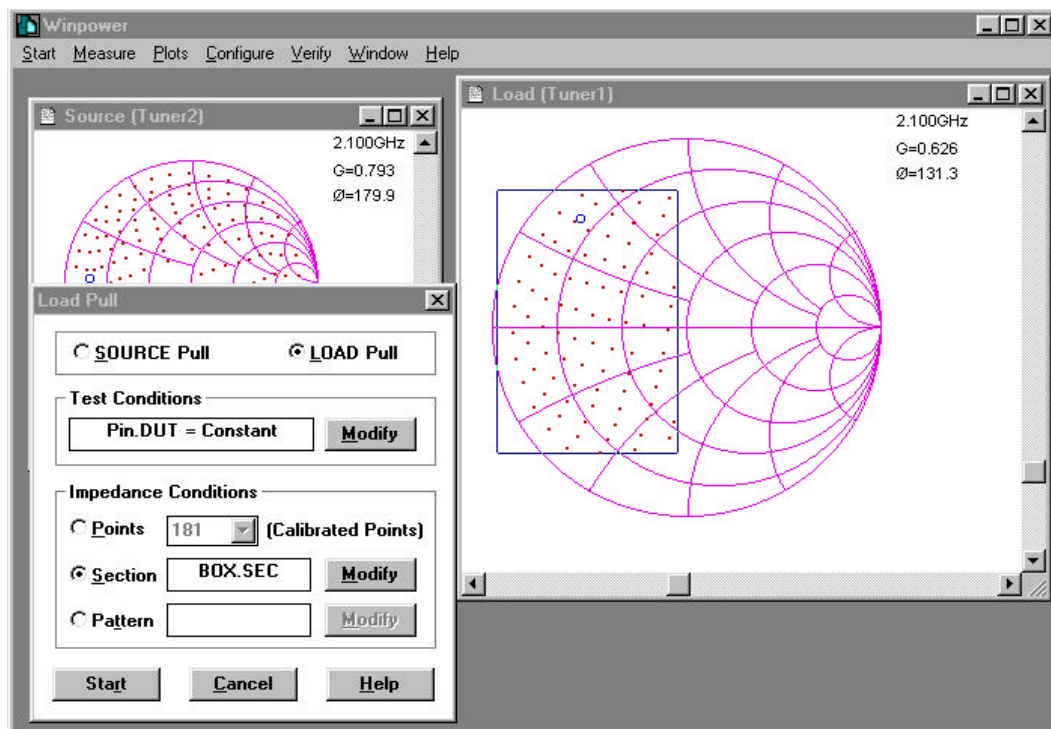

Figure 18 : WinPower Load Pull measurements using a ‘Section Pattern’.

All DC currents and voltages are also measurable. The measurements can be made either for constant input power or for regulated input power in order to maintain another parameter constant (such as Output Power, Gain, Intermod, ACPR, Id, Efficiency etc..).

The data is processed to ISO Contours or 3D surface plots, which may be printed on paper or converted to various types of graphic files for further processing. All data is available in ASCII (text) format as well.

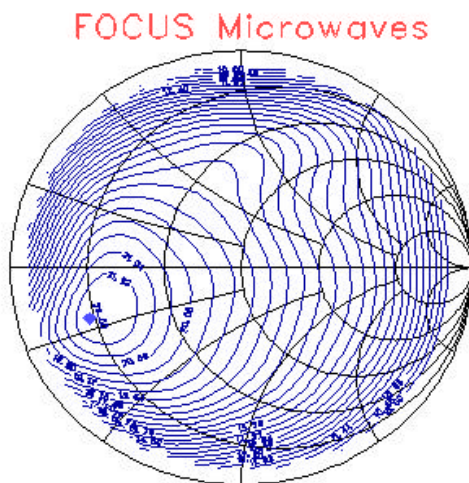

Fig.19: Iso-Contours of Pout at 12 GHz

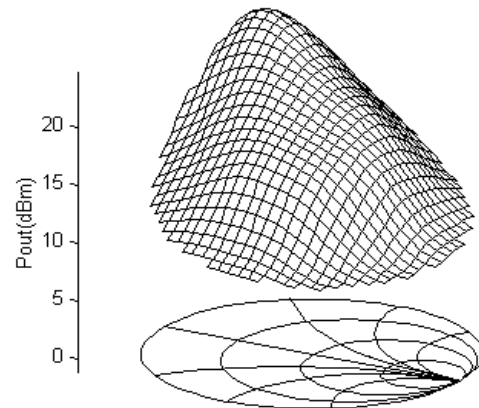

Fig. 20: 3D Surface Plot of Pout at 12 GHz

The impedance measurement range can be restricted by the user either by defining an Impedance Pattern (defined using Mouse-Tuning or a Pie-type with up to 400 impedance points) or a rectangular Section of the Smith Chart to be included or excluded from the measurements.

Other routines and options included in the CCMT Load Pull Software:

- **Fast Peak Search** of Source or Load Impedance for Maximum Gain, Power or Efficiency.
- Automatic or manual **Saturation measurements** and generation of plots of any of the measured quantities as a function of input power.
- **AUTO-START**: Restart the operation at the last configuration using "single-key" control.
- **MACRO-FILE**: Constitutes a genuine 'Tuner Programming Language' : Executes Tuning, Biasing, Load Pull, Peak Search or Compression measurement, as well as File Saving and Search operations driven from a user defined Script (ASCII) file.
- **Design Verification**: The tuners are driven to impedances included in S2P files to emulate the source and load conditions in a future circuit and thus test the amplifier performance before the first physical iteration.
- **Design single stage wideband high power amplifiers** using load pull contours and the program μ W-PADS.

Other software packages permit the calibration of the tuners and the harmonic tuners, the setup, the test fixture (using FOCUS generic TRL method^(*)), adapter removal and measurement of S-parameters and

DC-parameters (IV-curves) for the transistors in the test fixture (includes TRL, TRM and OSL calibration of the fixture and de-embedding).

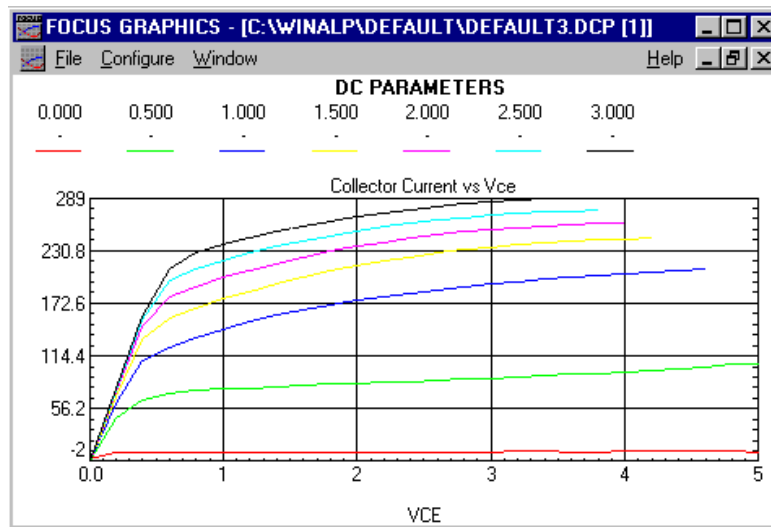

Figure 21: IV-curves of bipolar transistor measured using CCMT software.
 ⇒Click on any interpolated point of the curves to bias the transistor automatically.

(*) The FOCUS generic TRL method can be used also on non-50Ω fixtures and probes using a 50Ω Delay Line standard.

CCMT System, Measurement and Data Processing Software

The CCMT system includes all software components needed for a complete system integration, starting with component calibration, measurements... and ending with 'in-situ' design verification and single stage power amplifier design, based on load pull data.

The CCMT System Software includes :

System Configuration, Tuner Manual Control, Data Conversion to ASCII, GPIB direct Communication, Tuner Calibration, Setup Calibration, Test Fixture TRL Calibration, In-Situ system and tuner calibrations, Harmonic tuner and setup calibrations.

Load Pull Measurement Software WinPower

The Basic Package includes :

Deembedding to Fixture or DUT reference plane, Automatic Load / Source Pull at Psource=Constant, Mouse Tune and Measure, Automatic Peak Search (Power, Gain, Efficiency) , Cursor (Scroll bar) Tune, keyboard entry of Impedances to tune to, Automatic DUT Biasing, Measure on Pattern / Section of Smith Chart, User Defined Instrument Control, DC IV-Curve measurement.

The quantities that can be measured in the basic package are:

Output Power, Transducer Gain, Two Tone Intermod, Intercept, Efficiency, DC Power, DC Bias, Gain Compression.

Extended measurement routines are included in optional modules as follows:

Extended Load Pull #1 ('Macro'):

MACRO file, DUT Large Signal Impedance, Fine and Pattern Peak Search, Compression Peak Search, Source Pull under Pin (DUT) =Constant, Display Harmonic Impedances.

Extended Load Pull #2 ('Advanced Spectrum'):

High Order Intermod (up to 4 tones), Adjacent Channel Power (ACPR), 'auto' and 'custom'.

Extended Load Pull #3 ('Design Window'):

AM/PM Load Pull, Design Window & Compression Load Pull, Optimize DC Bias for Max Pout/Gain/Efficiency, Oscillator Load Pull, RF pulse measurements, Power Data Manager (PDM).

Extended Load Pull #4 ('Constant Pout'):

Load Pull for Constant: Pout, Gain, Efficiency, Intermod, ACPR, Output Current (obtained by regulating automatically the signal source power).

Graphics Software

- Contour and 3D surfacing Software, WinGraph,
- Cartesian (X-Y) plots, S-parameters, Saturation Pin/Pout plots & DC-curves, WinPlot,
- 'Surfer' Software for user scalable, colored contours & 3D Plots,
- 'PSP' Software for saving and processing graphic files in .TIF format.

Other software modules available to support Load Pull Measurements :

- Harmonic Load Pull (HLP); additional hardware (PHT) required, see page 18,
- Design Verification Software (DVP),
- Microwave Power Amplifier Design Software (μ W-PADS),
- Independent Test Fixture Characterization (TRL, TRM, OSL), S-parameter measurement and Adapter Removal Software (S2PMES),
- HP-VEE driver for tuner control and tuning (DDE and DLL),
- MATLAB driver for tuner control and tuning (DDE and DLL),
- GPTC (General Purpose Tuner Controller) software for tuner calibration, control and tuning,
- LABVIEW driver for tuner control and tuning (DDE and DLL).

Noise Measurement Software, WinNoise

'Hot-Cold' and 'Cold' noise source measurements, Noise Figure Source Pull, 'on-wafer' noise measurements, Automatic Search for NF_{min} ; Automatic measurement of 4 noise parameters; Noise Parameter de-embedding (*) Mouse impedance pattern (any tunable point); Repeat measurement on Pattern; Verification of Noise Figure on any point of the Noise Circles, including NF_{min} ; Noise, Gain and Stability Circles, Stability factor K; Frequency sweep mode; Double sideband (DSB) error correction.

Results are available in cartesian, Smith Chart or ASCII file listing format (see figures 11 and 12).

(*) Allows you to measure noise parameters at test-fixture ref. plane where Γ_{opt} is lower and tuning range higher and correct back to DUT ref. plane using noise correlation matrices.

Related Products and Accessories

- **Integrated Load Pull System, ILPS (PN-47)**

represents a "turn-key" solution for customers who need a complete system, integrated and tested at the factory in respect to its critical elements, like the tuners, controller and signal conditioning and processing components. ILPS software allows for "in-situ" calibration on a Vector Network Analyzer, without removing or disconnecting components.



- **GPIB Tuner Controller, ETC (PN-49)**

The external GPIB tuner controller is a stand-alone instrument that can be directed by any computer with GPIB interface to control up to four tuners (two CCMT and two PHT) as well as two remote RF-switches. ETC also includes a 3.5" floppy disk drive and offers ⇒access to external monitor and keyboard for local operation.



- **Coaxial TRL Calibration Kits (0.1 to 50 GHz)**

TRL (Thru-Reflect-Line) calibration of network analyzers provides the highest accuracy. ⇒This is required for load pull tuner calibrations. The Focus Microwaves TRL calibration kits cover 0.1 to 50 GHz in five models: GPC-7, -3.5mm, -2.9 (K), -2.4mm and N-connectors. The coaxial TRL calibration kits are very robust, easy to use and provide state of the art calibrations of all Hewlett-Packard® and Wiltron® network analyzers up to 50 GHz, in a comprehensive manner. See also PN-2 and AN-13.



- **RF Power Transistor Test Fixtures (DC to 18 GHz)**

The modular test fixtures are designed for S-parameter and load pull tests of packaged transistors in the frequency range DC to 5 GHz (PTJ-0) and 18 GHz (PTJ-1). Connectors: GPC-7, N or SMA. PTJ-x test fixtures are a cost-effective solution for testing up to 100 Watt transistors especially in Load Pull; the fixtures are supplied with 50Ω transmission lines or prematching transformers, one transistor insert and TRL calibration standards. Options: Customized transistor inserts, TRL data (S2P ASCII data of both fixture halves on diskette), integrated BNC bias supply, ⇒heat radiators, water cooling capability and fast replacement transistor clamp. See PN-2.

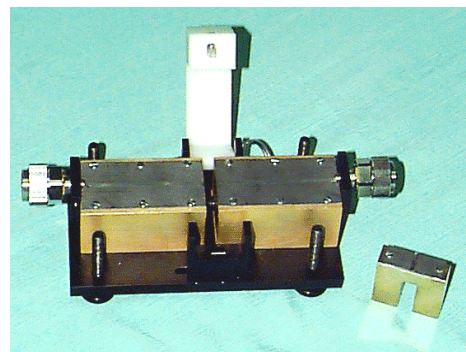

- **RF-Switch Control Box for automatic Noise and Load Pull Setups**

The RF-switch Control Box, SCB-2D, is used for on-wafer Load Pull and Noise measurements. The SCB-2D interfaces between the system PC and two remotely controllable RF-switch relays with no need for an external DC power supply. The switches can be set using front panel push buttons or via software, manually or automatically. See PN-32.



- **Programmable Harmonic Tuners**

Programmable Harmonic Tuners (PHT) are able to selectively generate and independently control high reflection factors ($\Gamma \approx 0.85-0.95$) at predefined harmonic frequencies ($2fo, 3fo = 1.6...65$ GHz). PHTs are available either as harmonic tuners only (for $2fo$ and $3fo$) or as a combination of fundamental and harmonic tuners ($fo, 2fo$). PHT can be included in existing load pull setups and used to optimize the harmonic load conditions independently of fundamental frequency tuning. Standard PHT models control two harmonic frequencies. A source and a load PHT can be controlled by a separate tuner controller installed into the load pull system computer or by the external tuner controller ETC. See PN-44.



- **Manual Microwave and Harmonic Tuners (PN-45)**

Manual Microwave Tuners (MMT) are designed for critical RF impedance matching operations from 0.4 to 50 GHz. The tuners use one or two sliding carriages with one vertical micrometer screw and a microwave probe (slug) each. The microwave tuners generate high reflection factors over a very wide frequency band (such as 0.8 to 18 GHz or 2 to 40 GHz with typical VSWR of 20:1). The two independently adjustable carriages allow mutual prematching of the probes and thus selectively generate extremely high VSWR (~50:1). The sliding mechanism and the probes ensure long lasting operation, high stability and reproducibility.

Manual Harmonic Microwave Tuners (MHMT) use resonant RF probes and can generate very high VSWR (~40:1) at harmonic frequencies, while the wideband probes can match the device independently at the fundamental frequency.

MHMTs are available either as harmonic tuners only or as a combination of fundamental and harmonic tuners. MMTs and MHMTs are available with GPC-7, N, 3.5, 2.9 (K) and 2.4 mm connectors.

The picture shows a MHMT-308 (for $fo=0.8-3$ GHz and $2fo=1.9$ GHz) and a MHMT-308-3H (for $3fo=2.85$ GHz). MHMTs are available up to 18 GHz as standard items and up to 40 GHz on special order.

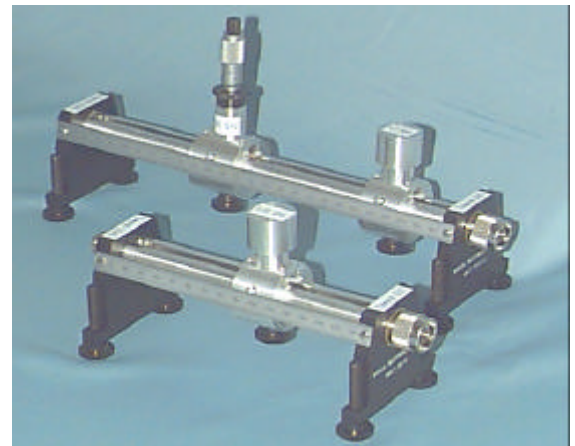

Application and Product Notes

(available upon request)

Application Notes

1-89 Two Tone Intermod Measurements using the CCMT
1-90 Noise Measurements using the CCMT
2-90 Microwave Oscillator Testing using the CCMT
1-92 Design a Power Amplifier stage using μ W-PADS
1-93 The CCMT- μ W-PADS Work Station
2-93 The MTS-rf-PADS Work Station
AN-5 User Defined GPIB drivers for the CCMT System
AN-6 Load Pull Measurements on Very Low Impedance Transistors
AN-8 Basics on Load Pull and Noise Measurements
AN-9 Power Efficiency Measurements using the CCMT
AN-11 Load Pull Measurements on Transistors with Harmonic Impedance Control
AN-12 AM/PM Distortion Load Pull of Power Transistors
AN-13 Calibration Techniques of Network Analyzers for Tuner Characterization
AN-14 On-Wafer Load Pull and Noise Measurements using Computer Controlled Microwave Tuners
AN-15 High Resolution Tuners Eliminate Load Pull Performance Errors
AN-18 Accuracy and Verification of Load Pull Measurements
AN-19 On-Wafer Noise Parameter Measurements using Cold Noise Source and automatic Receiver Calibration
AN-22 Peak Search Algorithms of CCMT Software
AN-23 Selective Load Pull using Pattern and Section Tuning
AN-24 Concept for Load Pull Measurements with Harmonic Impedance Control
AN-25 High Reflection Load Pull: Possibilities and Tradeoffs
AN-26 Create your own Load Pull tests using MATLAB-TUNE
AN-28 Macro File Operation of the CCMT System
AN-29 In-situ Optimizing Output Power Stages of Mobile Phones

Product Notes

PN-2 Coaxial TRL Calibration Kits for Network Analyzers up to 40 GHz.
PN-3 The MTS Power Amplifier Design Work Station
PN-4 High Density CCMT Tuner Calibration
PN-5 V Band Programmable Tuner, Model 7550
PN-5A V Band On-Wafer Measurements using CCMT Model 7550
PN-6 Load Pull Characterization and SSPA Design Service
PN-7 Test Fixture for Medium and High Power RF transistors
PN-8 Measurement Routines of MTS and CCMT: a Comparison
PN-9 UHF to Ku Band Programmable Tuner, Model 304-CK
PN-10 6 to 40 GHz Coaxial Programmable Tuner, Model 4006
PN-11 4 to 26.5 GHz Coaxial Programmable Tuner, Model 2604
PN-12 Software Packages for the CCMT System
PN-14 Rent a Load Pull or Noise Measurement System
PN-15 FOCUS.LIB 'C' Library for Tuner Control GPIB Operation
PN-16 GPIB Tuner Controller GPTC
PN-17 RF Tuner with Very High VSWR, Model MTS-308-HR
PN-18 Design Verification Software DVP
PN-19 GPIB Instrument Support CCMT, MTS
PN-20 Adjacent Channel Leakage Power Measurement - ACP
PN-21 Power Data Manager – PDM
PN-23 Tuner Control Plug for On Wafer Operation
PN-24 Setup Configurations for Very Low Impedance Tuning
PN-25 Tuner Operation using HP-VEE®
PN-26 Tuner and GPIB Operation Using MATLAB®
PN-27 TWIN Tuner Control and Measurement Software for Windows
PN-29 'MATLAB-TUNE', 'VEE-TUNE' and 'GPTC'- a Comparison

PN-30 Ultra Wideband Tuner System UTS

PN-31 Probe Holder for On Wafer operation of 33 to 110 GHz Waveguide Tuners

PN-32 RF Switch Control Box for automatic Noise and Load Pull measurement set-ups

PN-33 ALPS, An Active Load Pull System for PCN Applications

PN-34 LSM, Large Signal S-Parameter Module

PN-35 WinGRAPH, Load Pull Contouring Software for Windows

PN-36 WinPLOT, Cartesian and Polar Plot Generation Software for Windows

PN-37 0.8 to 18 GHz Tuner with Very High VSWR option HR-308 and HR-1803

PN-38 RF-Switch Control Box for Automatic Noise and Load Pull Measurement Set-ups

PN-40 Active Harmonic Load Pull 'ALPS' and Passive Harmonic L/P with Active Modules 'HLP-AM'

PN-41 Computer Controlled Microwave Tuner - CCMT

PN-42 Active Modules for Harmonic Load Pull Measurements

PN-43 W Band Programmable Tuner Model 11075

PN-44 Programmable Harmonic Tuner, PHT

PN-45 Manual Microwave Tuners, model MMT

PN-46 Programmable Load Pull Tuners for Fundamental and Harmonic Tuning, model CCMT-option H2/H3

PN-47 Integrated Load Pull System, ILPS

PN-48 2 to 40 GHz Coaxial Programmable Tuner Model 4002-2C

PN-49 External GPIB Tuner Controller, ETC