

**Focus Microwaves Inc.**

1603 St. Regis  
D.D.O., Québec,  
Canada H9B 3H7  
Tel: 514-684-4554 Fax: 514-684-8581  
E-mail: info@focus-microwaves.com



---

**Product Note 38**

## **RF-Switch Control Box for Automatic Noise and Load Pull Measurement Setups**

Focus Microwaves introduces a **new RF-switch Control Box for On-Wafer Load Pull and Noise Measurements**. A new Tuner Controller Interface Card eliminates the need for an additional analog card, model AB08R, which was required up to now for dedicated control of the RF switch-relays. This new **Tuner Control Card with Integrated Switch Control Option** can be connected directly to the **new Switch Control Box, model SCB-2D**. The SCB-2D can remotely control up to two RF-switch relays with no need for an external DC power supply.



Figure 1 : RF Switch Control Box, model SCB-2D

---

Product and Company names listed are trademarks of their respective companies and manufacturers.

© Copyright 1997 Focus Microwaves Inc. All rights reserved

May 1997

## Configuration

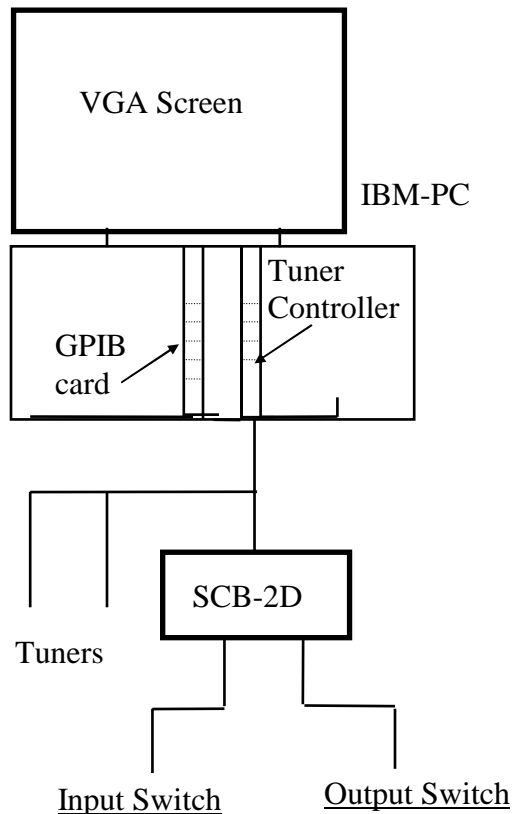

Figure 2 : Configuration of the SCB-2D

A Load Pull and Noise Measurement Setup consists of two programmable tuners, a Vector Network Analyzer ( VNA ), two power meters, a power supply, spectrum analyzer (for load pull) or a noise analyzer and noise source (for noise), all GPIB programmable, and other passive components such as bias tees, isolators and attenuators. The setup is remotely controlled by an IBM-PC compatible computer with tuner control and GPIB interface.

Automatic On-Wafer Load Pull and Noise measurement operations require “in situ“ use of a VNA **to be switched in and out of the setup during the measurement.** This is done automatically using remote control SPDT RF-switches. These switches can now be controlled automatically by the tuner software using the IBM-PC via the **new Tuner Controller Card with relay control option.** The new card has an extension 15 pin port that can be connected to a Switch Control Box , model SCB-2D. DC power is supplied to the SCB-2D directly from the PC. This new option can be configured at the factory to match a variety of commercial RF switches ( SP2T for Load Pull or Noise setup, SP3T for Load Pull and Noise setup or Transfer switches).

The new automatic controller configuration includes :

1. The new Tuner Controller card with “R” option, model **CC-2R.**
2. A Switch Control Box, model **SCB-2D**

This means that the Analog card AB08R will not be required any more and Focus Microwaves will stop manufacturing and supplying it starting June 1997. On the other hand, the Customer still has to purchase the two appropriate RF-switch relays that will operate with the switch control box SCB-2D.

Focus Microwaves offers the following additional options :

**-2RFS:** Two RF (latch) switches ( DC-18 GHz ) already connected and tested with the switch box.

**-NS:** A switch box with BNC-type connector for noise source ON/OFF control. This option is required for Noise Measurements using a Spectrum Analyzer.